

SERVICE INSTRUCTIONS

Mercotac® connectors contain a small amount of liquid mercury and should be disposed of properly through recycling. Mercotac, Inc. offers a recycling service for this purpose. When shipping spent units to Mercotac Inc., insert products into a plastic bag and package items being returned for UPS Ground shipment. Please state on paperwork "For Recycling", and identify shipments with company name and Phone / FAX numbers. (Do not send through USPS.)



6195 Corte del Cedro, #100
 Carlsbad, California 92011, USA
 Ph 760 431 7723 Fax 760 431 0905
 e-mail: info@mercotac.com

1. Mercotac® connectors can be used both horizontally and vertically. However the "UP" arrow on the body of the connector should not point below horizontal. It is preferable to store units upright (arrow up). <Fig 1>



Fig 1

DIMENSION "A" +.001(.025) -.0	
MODEL	HOLE SIZE
105	.283(7.19)
110	
205	
305	.408(10.36)

Fig 2 Receptacle press-fit Dimensions

2. The connector can be held or mounted by the body or the receptacle <Fig 2>, and was not designed to carry mechanical loads. One end should be allowed to float, attached only by the connecting wires. In horizontal applications mount the connector with the body rotating to reduce mechanical loads on the bearing. (Model 110 may be excepted). There is a spring tension fit between the cap or receptacle and the contacts. The cap is usually mounted to the bearing end. <Fig 3>. **Never rigid mount both ends of the connector. This will cause connector failure.** Limit mounting eccentricity to .005" (.13mm).

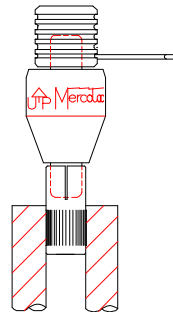

Fig 3 110-T Mounting

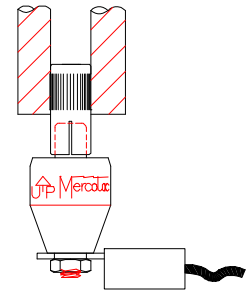

Fig 4 110 Mounting

3. The connectors are reversible (except model 110), so they need not be installed upside down <Fig 4>.

4. **Do not solder to the connector as such misuse may cause connector failure and voids the warranty.**

5. Use stranded wires of ample length and flexibility to avoid mechanical loads. Avoid taut wires that pull on the connector. The wires should have enough free play to allow the connector end to rotate approximately 1/4 turn. Wires that allow too much free play could wrap around the connector.

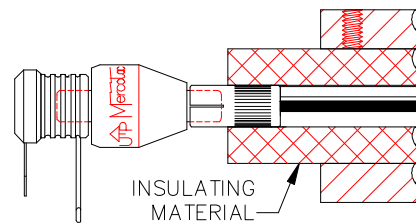

Fig 5 Thermal Insulation

6. Provide current protection (fuse) on wires attached to connector. Over-current conditions can cause failure of connector. **CAUTION:** The aluminum body may be electrically "hot" after failure. Disable power source before handling a suspected failed connector.

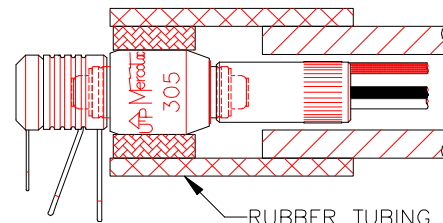

Fig 6 Vibration Isolation

7. The connector contains plastic materials that are sensitive to heat. Over-heating will cause reduced life or connector failure. Provide thermal insulation where necessary to prevent temperature of the unit from exceeding 140°F (60°C). <Fig 5>

8. Vibration and mechanical shock will reduce life or cause connector failure. Some installations may require a shock isolating mounting, such as rubber tubing. <Fig 6>

9. In food and packaging applications:

Mercotac® connectors contain liquid mercury and other fluids. **Isolate connector from the food processing area by using a protective housing.** Short circuit failure at or in connection with a Mercotac® connector rarely but occasionally may result in leakage. The use of a protective housing may be advisable in these applications. <Fig 7>

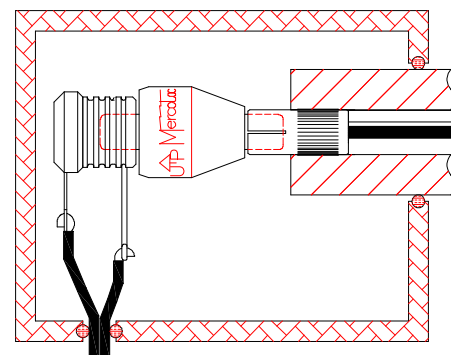

Fig 7 Protective Housing

COAX SERIES



6195 Corte del Cedro #100, Carlsbad, CA 92011, USA
 Ph 760 431 7723 / Fax 760 431 0905
 e-mail: info@mercotac.com

MODEL 110
1 pole

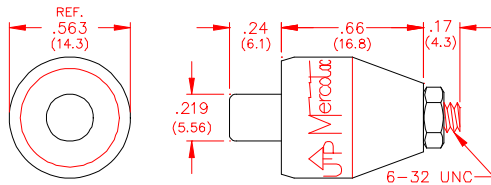

ORDER ACCESSORIES SEPARATELY

MODEL 110-T & 105
1 pole

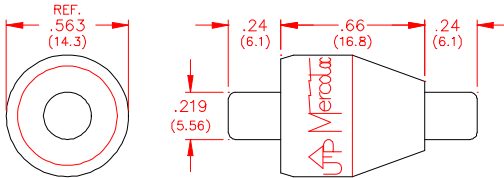

MODEL 205
2 pole

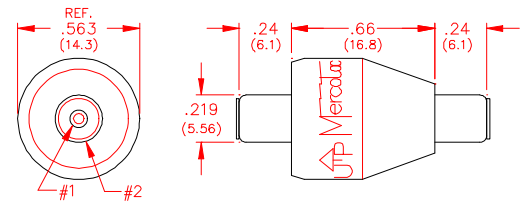

ORDER ACCESSORIES SEPARATELY

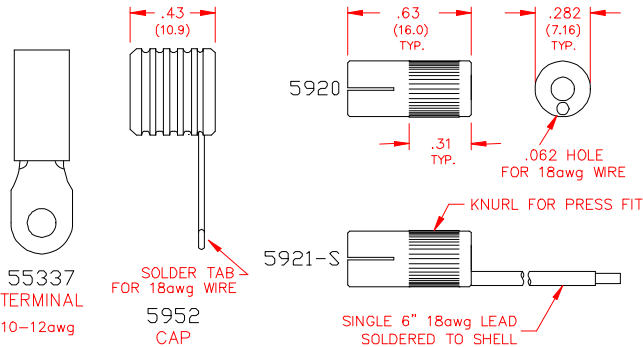

SINGLE CONDUCTOR ACCESSORIES

TOLERANCES	x.xxx (x.xx) ±0.001 (±0.025)
INCHES (mm)	x.xx (x.x) ±0.010 (±0.25)

WARRANTY: Units are guaranteed for one year from date of purchase against defective materials and workmanship. Replacement will be made except for defects caused by abnormal use or mishandling. All statements and technical information contained herein, or presented by the manufacturer or his representative are rendered in good faith. User must assume responsibility to determine suitability of the product for intended use. The manufacturer shall not be liable for any injury, loss or damage, direct or consequential arising out of the use, or attempt to use the product.

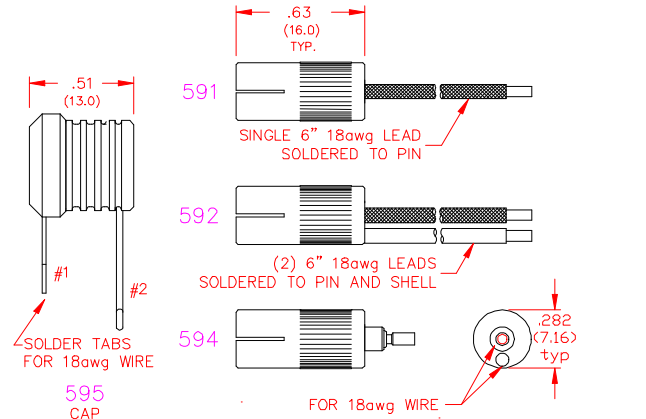

TWO CONDUCTOR ACCESSORIES

MODEL 305
3 pole

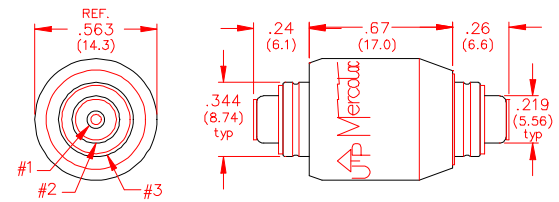

ORDER ACCESSORIES SEPARATELY

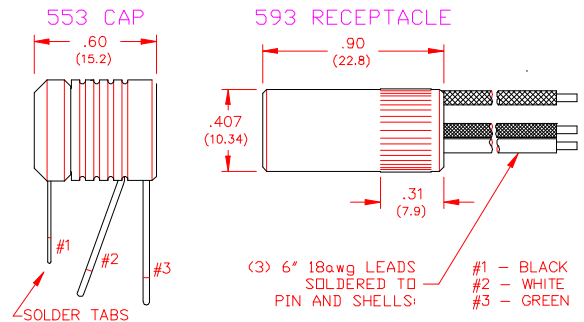

THREE CONDUCTOR ACCESSORIES

TECHNICAL SPECIFICATIONS

SPECIFICATIONS	MODEL NUMBER						
	105	110 /-T	110-L/TL	205	205-H	205-L	305
CONDUCTORS	1			2		3	
VOLTAGE RANGE (V) AC/DC	n/a			0 - 250			
CURRENT RATING (A @ 240VAC)	4	10		4			
MAXIMUM FREQUENCY (MHz)	200						
MERCURY CONTACT RESISTANCE	< 1 milliohm						
MAXIMUM ROTATING SPEED (RPM)	7500	3600	1200	2000	3600	1200	1800
MAXIMUM BODY TEMPERATURE °F (°C)	212 (100)		140 (60)				
MINIMUM OPERATING TEMP. °F (°C)	45 (7)	-20 (-29)		45 (7)	-20 (-29)		
CIRCUIT SEPARATION	n/a			> 25 megohm			
TYP. ROTATIONAL TORQUE (NmX10-4)	< 10	35	10	75	35	20	100